

LED Flexible Strip 2835 Series

LM5050-WN42-RGB-S-12V



Product Feature

- ◆ **42** leds per meter, 5meters per roll, the theoretical power **10W/meter**, Actual power: W/m ,light angle 120 degrees. **27-30**lm per led chip.Can be customized according to needed.
- ◆ Flexible, cuttable,back with 3M double-sided adhesive,can be installed in the concave convex surface, easy to install.
- ◆ Led strip supports external light regulator type: 0/1-10V PWM Dali Dimmable inductive switch controller.
- ◆ Cutting unit is **71.43**mm, **3**led chips can be used as a unit, cutting does not affect other parts. Normal length is 5 meters, other lengths also acceptable.
- ◆ Low power consumption, low fever, no glare, impact resistance, energy saving and environmental conservation.
- ◆ LED can be customized to glue dust (IP65), (IP66), silicone casing plus glue waterproof (IP68);
- ◆ Life time: Mean time between failure(MTBF):50-100K hour



Technical Parameters

Mode	LED Q'ty/M	Color temperature		CRI(Ra)		Voltage (V DC)	Electric current (A/m)	Power ± 10%(W/m)			Lm/m ± 10%	FPC Width
				Min	Max			Actual	Min	Max		
LM5050-WN42-RGB-S-12V	42	White	6000-6500K	80+	90+	12				10		10mm
		Natural White	4000-4500K									
		Warm white	2200-3200K									
		Red	620-625nm									
		Blue	455-460nm									
		Green	520-525nm									
Yellow	590-592nm											

Dimension(mm/inch)

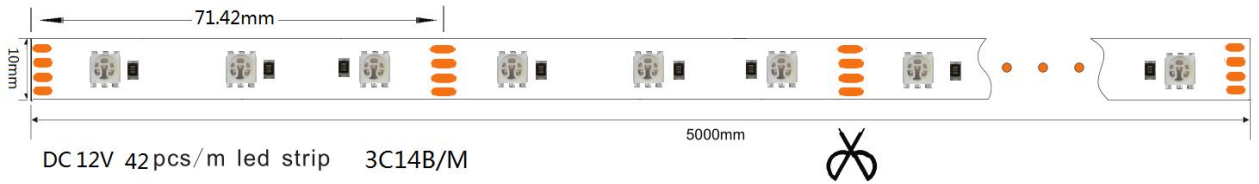

Product Electrical

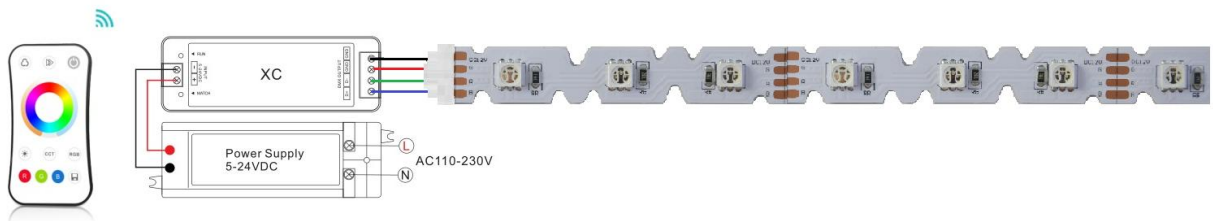

Linking Operation

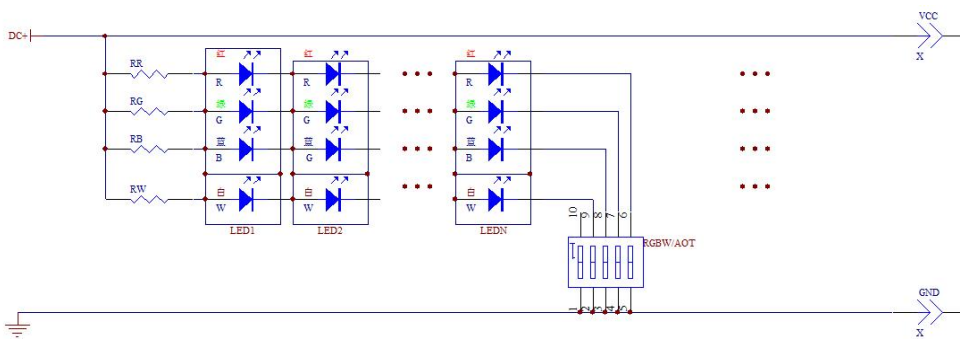

Installation

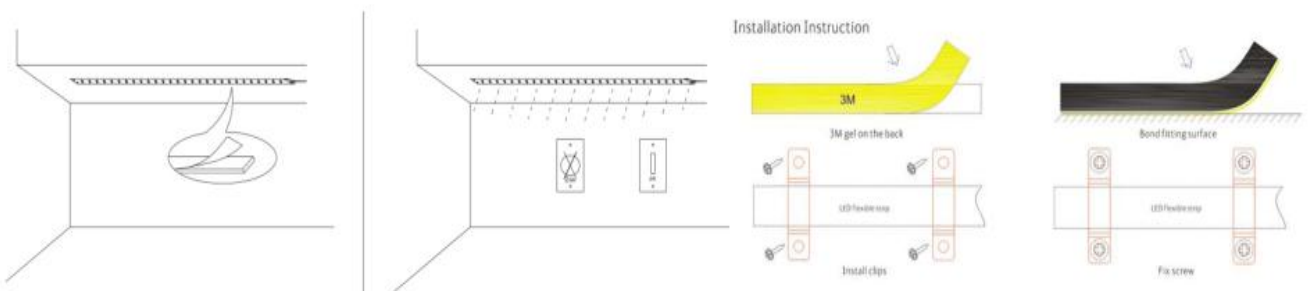

Product Packaging

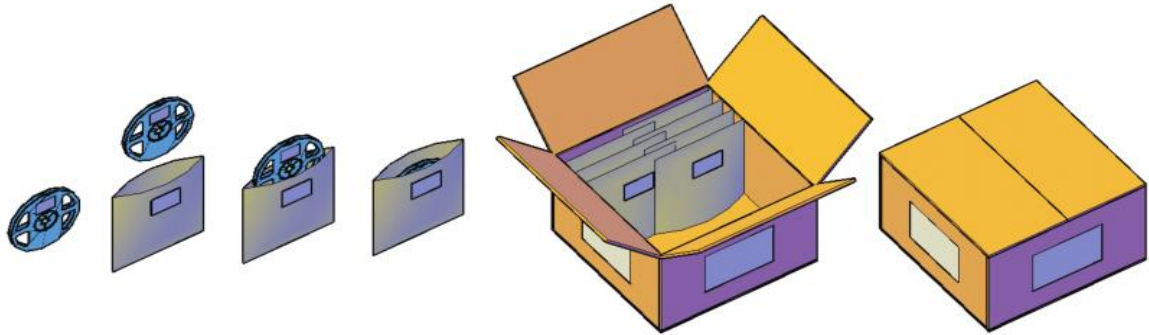

Safety Information

- The strip itself and all its components may not be mechanically stressed.
- Assembly must not damage or destroy conducting paths on the circuit board.
- Installation of LED ribbon (with power supplies) needs to be made with regard to all applicable electrical and safety standards. Only qualified personnel should be allowed to perform installations.
- Correct electrical polarity needs to be observed. Wrong polarity may destroy the strip.
- Parallel connection is highly recommended as safe electrical operation mode.
- Serial connection is not recommended. Unbalanced voltage drop can cause hazardous overload and damage the strip.
- Please ensure that the power supply is of adapters power to operate the total load.
- When mounting on metallic or otherwise conductive surfaces, there needs to be an electrical isolation points between strip and the mounting surface.
- Pay attention to standard ESD precautions when installing the strip.
- Damaged by corrosion will not be honored as a materials defect claim. It is the user's responsibility to provide suitable protection against corrosive agents such as moisture and condensation and other harmful elements.